

TOTAL GYM SPORT® ASSEMBLY AND SET-UP INSTRUCTIONS

TOTAL GYM SPORT BOX CONTENTS:

- Total Gym Sport Complete Assembly
- Folding Foot Holder
- Folding Platform
- Hardware & Information Box
- Telescoping Squat Stand

REMOVING TOTAL GYM SPORT FROM THE BOX

- 1 Remove the lid of the Total Gym® box and set it aside.

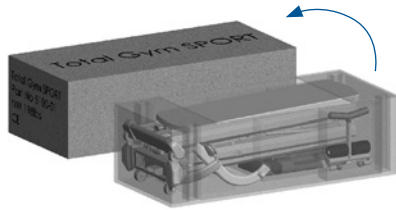

- 2 Remove all interior boxes from the top and sides. Cut the tape on the end of the box at the base of the tower. Unfold that end of the box.

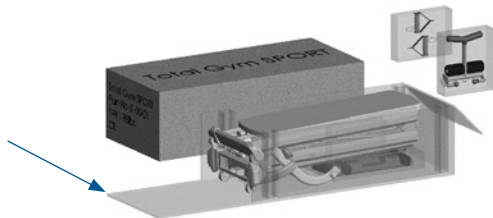

- 3 Stand the Total Gym Sport® upright and roll it to the location where you want the tower to stand.

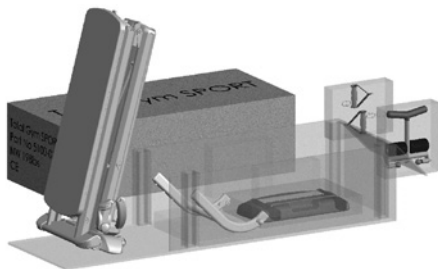

- 4 Remove the folding platform and the telescoping squat stand parts from the bottom of the box.

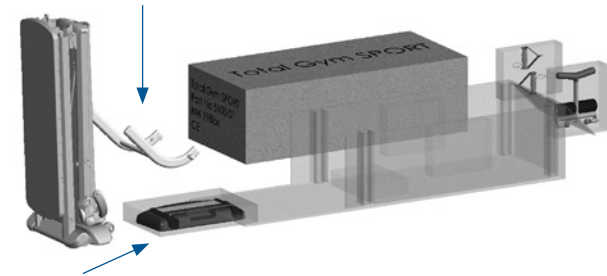

UNFOLDING TOTAL GYM

- 5 Unlatch the rails from the tower.

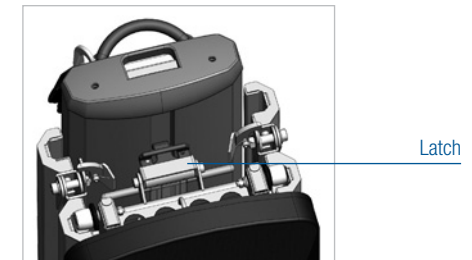

- 6 Standing at the side of the unit, with one hand behind the tower and the other hand on the glideboard, tilt the unit slightly backward and use your foot to push the rail base away from the tower. The tower will follow the upper rails forward and then it will begin to pull away from the rails, backward to an upright position.

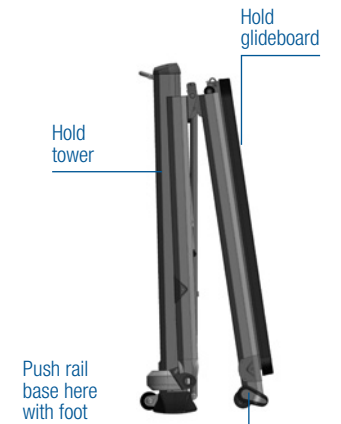

Caution! The tower is designed to open automatically by pulling away from the upper rails as the rails begin to unfold. Do not force or push the tower away from the rails, as this may cause the tower to fall backward.

TOTAL GYM SPORT® HARDWARE & INFORMATION BOX CONTENTS:

- Quick Links (2)
- Assembly Instructions and Owner's Guide
- Strap Handles (2)
- Assembly, Set-up and Storage DVD

TotalGym.com

U.S. Customer Service: 858.586.6080

7 When the tower begins to pull away from the upper rails, grasp the upper rail where indicated on the inside of the rail just above the hinge (indicated on both sides) and continue to unfold the rails and lower them to the floor. As the rails straighten, guide the glideboard rollers into the groove of the upper rail if needed.

Caution! As the rails get close to the floor, the rails feel heavier. To avoid pinching the rollers in the hinges, do not drop the rails.

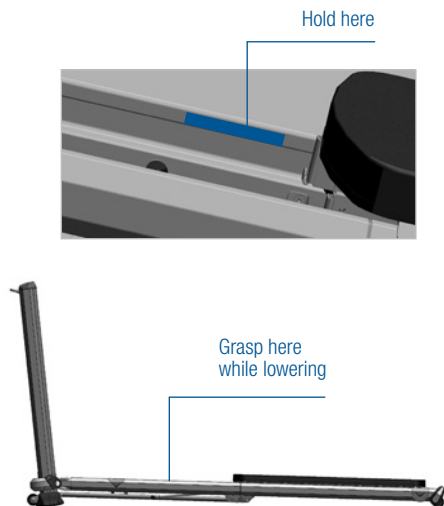

ADJUSTING THE INCLINE OF THE RAILS

RAISING THE INCLINE OF THE RAILS

Note: Slightly lift the rails, then depress the release handle on the top of the tower. Then continue to lift the rails to avoid a ratcheting sound.

- 8** Stand next to the tower.
- 9** Grasp the upper rail near the tower. Lift to the desired level. Incline scale is located on the side of the tower.

Note: When the folding foot holder is attached after assembly, grasp the rails above the folding foot holder when lifting, to avoid pinch areas. Do not hold rails below the folding foot holder attachment.

- 10** Push the rail down to insure it engages into the tower.

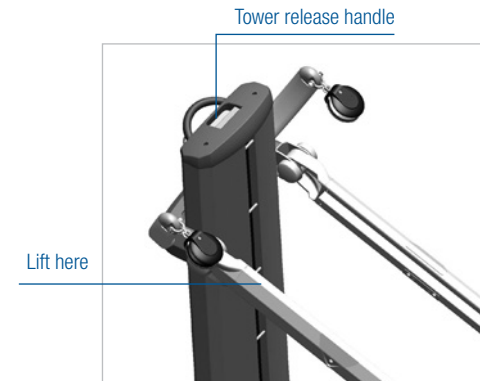

LOWERING THE INCLINE OF THE RAILS

Note: Slightly lift rails; squeeze the release handle; move rails as desired.

- 11** Stand next to the tower.
- 12** Grasp the rail near the tower and above the folding foot holder and lift it slightly.
- 13** With the other hand, squeeze the release handle on top of the tower to unlock the tower cross arm.
- 14** Continue squeezing the release handle and lower the rails to the desired level. Incline scale is located on the side of the tower. When you have reached the desired level, let go of the release handle.
- 15** Push the rails down to ensure they engage into the tower.

total gym®

FOLDING FOOT HOLDER INSTALLATION

Your Total Gym Sport® arrives with the folding foot holder, which needs to be installed. Remove the folding foot holder from the box and install it on the upper rails.

- 16** Place the rails at or above level 10 so you have room to install the folding foot holder from underneath the rails. Aim one pin into the hole of a rail while holding the folding foot holder upper bar even with the middle of the rails.



- 17** Continue to hold the folding foot holder upper bar even with the middle of the rails. Pull the pin on the other side. Align and insert it into the hole in the opposite rail, and release the pin. Ensure both pins are fully engaged in the rails.

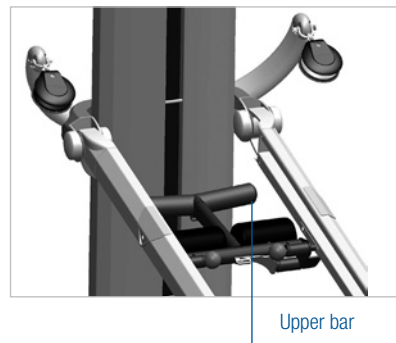

- 18** **Folding Foot Holder Use Position:** Pull up on the upper bar to engage the folding foot holder for use. Depress the lever where indicated to fold down when not in use.

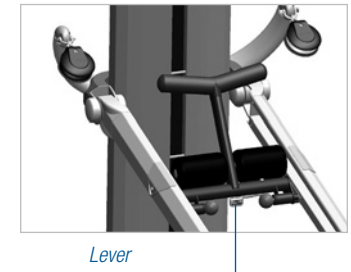

TELESCOPING SQUAT STAND ASSEMBLY

There are two attachments that make up the telescoping squat stand assembly—the folding platform attachment and the squat stand attachment.

FOLDING PLATFORM ATTACHMENT

- 19** Stand at the base of the rails facing the tower. Hold the folding platform with a hand on each post. Partially angle the posts toward the glideboard. Align the upper fixed pin on the left with the top hole on the lower rail. Allow the lower pull-pin to press against the plate on the left side of the rail as you guide the upper fixed pin into the hole.



- 20** When the fixed pin is inserted into the hole gently move the folding platform to the right. Then lower the right side of the folding platform down to align the right pull-pin into the plate on the right lower rail as shown below. You may need to pull the right pull-pin.



- 21** When both left and right pull-pins are engaged into the rails, rotate the folding platform away from the glideboard until the lower pull-pin on the left side pops into the rail hole. To fold the platform for storage, simply disengage the lower left pull-pin and fold the platform (the squat stand will be attached).



TELESCOPING SQUAT STAND ATTACHMENT

- 22** Lift the release lever on the back of the telescoping squat stand. Align the squat stand receptacle posts over the folding platform posts. Slide the squat stand down and align it with one of the three levels indicated by the holes in the posts. Release the lever to lock the squat stand into place.



- 23** Inspect the lever and pull up on the squat stand handle to insure the squat stand is locked in on both sides.

INSTALLING THE HANDLES

- 24** Open the hardware box and remove the handles and threaded quick links as shown. Install them on each end of the cable.

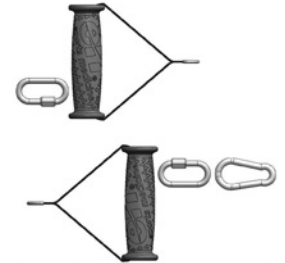

ALMOST FINISHED

- 25** When the assembly is finished, look for extra parts to ensure no steps were missed. Inspect your Total Gym® for defects and contact Customer Service if you feel you have any problems. Before using your new Total Gym, read the safety and usage instructions in the Owners Guide.

YOUR TOTAL GYM SPORT® IS NOW READY TO USE.